

## Portable Welding Fume Extractor



### Description

The PHV is a portable high vacuum welding fume extractor. It is equipped with two motors and an automatic start/stop device. The extracted welding fume first passes a metal pre-separator and then goes through the Dura-H main filter with integrated aluminium pre filter. The air leaves the unit through a HEPA filter. An activated carbon filter can be installed as an option.

With its wheels, the handle and its compact design the machine is extremely suited to be used in relatively small workshops, in confined spaces or near sources of pollution without a fixed location. The PHV can be switched on/off manually or automatically.

The B(G)IA-W3 certified PHV-I version is additionally provided with a filter pollution indicator and sound signal.

### Applications

The PHV is intended to be used for the following applications:

- MIG-MAG/GMAW welding
- TIG welding
- FCAW welding
- stick/MMAW welding



Do **not** use the PHV for the following applications or in the following circumstances:

- arc-air gouging
- oil mist
- heavy oil mist in welding fume
- extraction of aggressive fumes and gases (e.g. from acids, from alkaline, from soldering paste containing lithium)
- extraction of hot gases (more than 45°C/113°F continuously)
- grinding aluminum and magnesium
- flame spraying
- extraction of cement, saw dust, wood dust etc.
- sucking cigarettes, cigars, oiled tissues and other burning particles, objects and acids
- explosive environments or explosive substances/gases



### Specifications

• Physical dimensions and properties	
Material housing	polypropylene
Colour:	
- Base + top cover	- grey RAL 7024
- Filter cartridge + wheel covers	- yellow RAL 1028
Weight (net)	18,6 kg (41 lbs)



Supply cable	
• Filters	
Material:	
- Pre filter	- aluminium + neoprene
- Dura-H main filter	- cellulose fibres + cardboard + aluminium
- HEPA filter	- cellulose fibres with polypropylene housing
- FAC HV (option)	- polyester fibres with activated carbon
Filter surface area:	
- Pre filter	- 0,037 m <sup>2</sup> (0.4 ft <sup>2</sup> )
- Dura-H main filter	- 11 m <sup>2</sup> (118.4 ft <sup>2</sup> )
- HEPA filter	- 0,4 m <sup>2</sup> (4.3 ft <sup>2</sup> )
- FAC HV (option)	- 0,073 m <sup>2</sup> (0.79 ft <sup>2</sup> )
Efficiency:	
- Pre filter	- 65% < 80%
- Dura-H main filter	- >95% (particle size: 0,3 µm)
- HEPA filter	- >99,5% (particle size: 0,3 µm)
Filter class:	
- Pre filter	- G2 according to DIN EN 779
- Dura-H main filter	- H10 according to DIN EN 1822
- HEPA filter	- H12 according to DIN EN 1822
• Performance	
Max. extraction capacity	- speed LOW: 160 m <sup>3</sup> /h - speed HIGH: 230 m <sup>3</sup> /h
Noise level according to ISO 3746	- speed LOW: 63 dB(A) - speed HIGH: 70 dB(A)
• Electrical data	
Power consumption	2 x 1000 W
Available connection voltages	115V/1 ~ /50-60Hz; 230V/1 ~ /50-60Hz
Protection class	IP 50
Stop delay	15 seconds
• Ambient conditions	
Min. operating temperature	5°C (41°F)
Nom. operating temperature	20°C (68°F)
Max. operating temperature	45°C (113°F)
Max. relative humidity	80%
Outdoor use allowed	no
Storage conditions	- 5-45°C (41-113°F) - relative humidity max. 80%
• Available options	
FAC HV	activated carbon filter
MBH	wall bracket
HCH 45	hose connection
NKT, NKC	nozzle kit
EN 20	funnel nozzle
EN 40	slit extraction nozzle
H2.5/45, H5.0/45	extraction/exhaust hose
CP 45	connection piece
• Scope of supply	
Portable welding fume extractor - Extraction hose 2,5 m (8.2 ft)/Ø 45 mm (1.8 in.) incl. connection piece - Spare carbon brush (4)	

<ul style="list-style-type: none"> <li>Order information</li> </ul>	
Article number:	
- 7608001000	PHV 115V/1 ~/50-60Hz
- 7603001000	PHV 230V/1 ~/50-60Hz
- 7603101000	PHV-I 230V/1 ~/50Hz
Number/package	1
<ul style="list-style-type: none"> <li>Shipping data</li> </ul>	
Gross weight	22 kg (48.5 lbs)
Packing dimensions	46 x 44 x 79 cm (18.1 x 17.3 x 31.1 in.)
Max. number/pallet	15
Harmonized Tariff Code	84213920
Country of origin	the Netherlands
<ul style="list-style-type: none"> <li>Approvals/certificates</li> </ul>	
	
	certificate no. 2027287.01 (issued April 5, 2004) EMC 89/336/EEC: certificate no. 2027287-QUA/EMC 04-4232 (issued April 5, 2004)
	BGIA W3 (PHV-I) certificate no. 200324535/1140 (valid until March 31, 2009)
	EU Directive 2002/95/EC (RoHS) (valid as of July 2006)

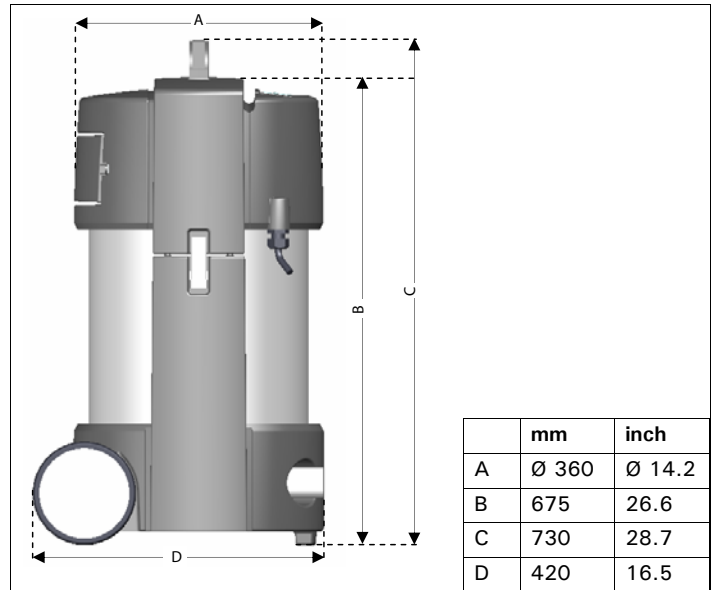
### Dimensions

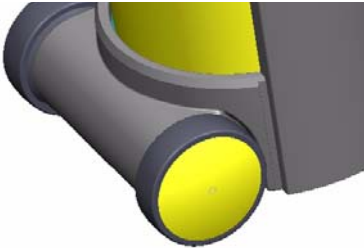

### Features

Standard wheel set	
Automatic start/stop device controlled by mass cable of welding machine	

Product type	: PHV
Art. no.	: refer to order information
Product category	: portable/mobile welding fume extractors
Version	: 170708/A

Euromate BV  
P.O. Box 9350  
1800 GJ Alkmaar  
The Netherlands  
www.euromate.com

