

Exploded view MFS

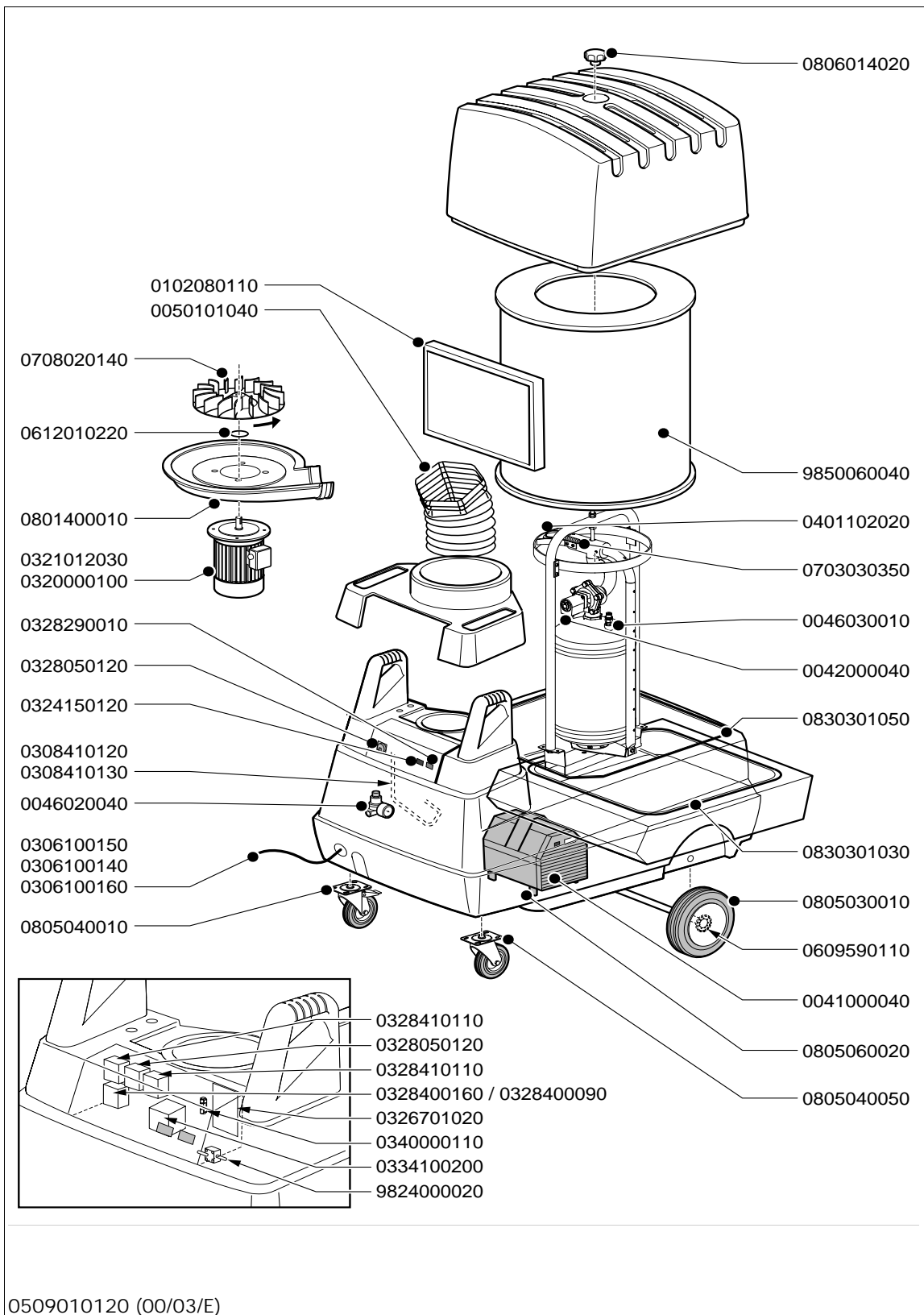

Spare parts MFS (400V/3ph/50Hz)

7045300000

Art. no.	Description
0042000040	Membrane valve
0046020040	Pressure regulating valve + pressure gauge MFS/SFS/SCS
0046030010	Pressure relief valve 8-12 bar
0050101040	Hose set (Ultra)Flex
0102080110	Spark arrester MFS/SFS
0306100140	Mains flex mobile units 4x1 mm ²
0308410120	Motor cable mobile units 4x1 mm ²
0320000100	Motor 0,75kW, 230-400V/3ph/50Hz
0324150120	Control lamp 24V, yellow
0326701020	PC board control MFS/SFS
0328050120	Main switch VCO
0328290010	Reset/start button
0328400090	Thermal relay NTR 1.7-2.4A
0328410110	Relay LS 5.10
0334100200	Transformer 50W/24V 115/230/400V
0340000110	Fuse 2,0 A
0401102020	Neoprene ring
0507260010	Manual Euromate MFS
0609590110	Starlock 22 mm
0612010220	Adjusting ring 19x1
0703030350	Spring cleaning unit
0708020140	Aluminium fan wheel
0801400010	Housing FAN 14/28/MNF/mobile units, motor side
0805030010	Wheel Ø 250 mm black
0805040010	Swivel castor Ø 125 mm with brake
0805040050	Swivel castor Ø 125 mm without brake
0806014020	Cover star knob M8
0830301030	Sealing dust drawer
0830301050	Sealing
0840101030	Bush Ø 203 mm
9824000020	Pressure difference switch MFS (800 Pa)
9850060040	Filter FCC 30

Spare parts MFS (230V/3ph/50Hz)

7043300000

Art. no.	Description
0042000040	Membrane valve
0046020040	Pressure regulating valve + pressure gauge MFS/SFS/SCS
0046030010	Pressure relief valve 8-12 bar
0050101040	Hose set (Ultra)Flex
0102080110	Spark arrester MFS/SFS
0306100140	Mains flex mobile units 4x1 mm ²
0308410120	Motor cable mobile units 4x1 mm ²
0320000100	Motor 0,75kW, 230-400V/3ph/50Hz
0324150120	Control lamp 24V, yellow
0326701020	PC board control MFS/SFS
0328050120	Main switch VCO
0328290010	Reset/start button
0328400120	Thermal relay NTR 3.0-4.7A
0328410110	Relay LS 5.10
0334100200	Transformer 50W/24V 115/230/400V
0340000110	Fuse 2,0 A
0401102020	Neoprene ring
0507260010	Manual Euromate MFS
0609590110	Starlock 22 mm
0612010220	Adjusting ring 19x1
0703030350	Spring cleaning unit
0708020140	Aluminium fan wheel
0801400010	Housing FAN 14/28/MNF/mobile units, motor side
0805030010	Wheel Ø 250 mm black
0805040010	Swivel castor Ø 125 mm with brake
0805040050	Swivel castor Ø 125 mm without brake
0806014020	Cover star knob M8
0830301030	Sealing dust drawer
0830301050	Sealing
0840101030	Bush Ø 203 mm
9824000020	Pressure difference switch MFS (800 Pa)
9850060040	Filter FCC 30

Spare parts MFS (230V/1ph/50Hz)

7042300000

Art. no.	Description
0042000040	Membrane valve
0046020040	Pressure regulating valve + pressure gauge MFS/SFS/SCS
0046030010	Pressure relief valve 8-12 bar
0050101040	Hose set (Ultra)Flex
0102080110	Spark arrester MFS/SFS
0306100160	Mains flex mobile units 3x1,5 mm ²
0308410130	Motor cable mobile units 3x1,5 mm ²
0321012030	Motor 0,75kW, 115-230V/1ph/50-60Hz
0324150120	Control lamp 24V, yellow
0326701020	PC board control MFS/SFS
0328050120	Main switch VCO
0328290010	Reset/start button
0328400130	Thermal relay NTR 4.0-6.3A
0328410110	Relay LS 5.10
0334100200	Transformer 50W/24V 115/230/400V
0340000110	Fuse 2,0 A
0401102020	Neoprene ring
0507260010	Manual Euromate MFS
0609590110	Starlock 22 mm
0612010220	Adjusting ring 19x1
0703030350	Spring cleaning unit
0708020140	Aluminium fan wheel
0801400010	Housing FAN 14/28/MNF/mobile units, motor side
0805030010	Wheel Ø 250 mm black
0805040010	Swivel castor Ø 125 mm with brake
0805040050	Swivel castor Ø 125 mm without brake
0806014020	Cover star knob M8
0830301030	Sealing dust drawer
0830301050	Sealing
0840101030	Bush Ø 203 mm
9824000020	Pressure difference switch MFS (800 Pa)
9850060040	Filter FCC 30

Spare parts MFS (115V/1ph/50Hz)

7048300000

Art. no.	Description
0042000040	Membrane valve
0046020040	Pressure regulating valve +
	pressure gauge MFS/SFS/SCS
0046030010	Pressure relief valve 8-12 bar
0050101040	Hose set (Ultra)Flex
0102080110	Spark arrester MFS/SFS
0306100160	Mains flex mobile units 3x1,5
	mm ²
0308410130	Motor cable mobile units 3x1,5
	mm ²
0321012030	Motor 0,75kW,
	115-230V/1ph/50-60Hz
0324150120	Control lamp 24V, yellow
0326701020	PC board control MFS/SFS
0328050120	Main switch VCO
0328290010	Reset/start button
0328400160	Thermal relay NTR 10-14A
0328410110	Relay LS 5.10
0334100200	Transformer 50W/24V
	115/230/400V
0340000110	Fuse 2,0 A
0401102020	Neoprene ring
0507260010	Manual Euromate MFS
0609590110	Starlock 22 mm
0612010220	Adjusting ring 19x1
0703030350	Spring cleaning unit
0708020140	Aluminium fan wheel
0801400010	Housing FAN 14/28/MNF/mobile
	units, motor side
0805030010	Wheel Ø 250 mm black
0805040010	Swivel castor Ø 125 mm with
	brake
0805040050	Swivel castor Ø 125 mm without
	brake
0806014020	Cover star knob M8
0830301030	Sealing dust drawer
0830301050	Sealing
0840101030	Bush Ø 203 mm
9824000020	Pressure difference switch MFS
	(800 Pa)
9850060040	Filter FCC 30

Spare parts MFS-BIA (230V/1ph/50Hz)

7042500000

Art. no.	Description
0042000040	Membrane valve
0046020040	Pressure regulating valve + pressure gauge MFS/SFS/SCS
0046030010	Pressure relief valve 8-12 bar
0050101040	Hose set (Ultra)Flex
0102080110	Spark arrester MFS/SFS
0306100160	Mains flex mobile units 3x1,5 mm ²
0308410130	Motor cable mobile units 3x1,5 mm ²
0321012030	Motor 0,75kW, 115-230V/1ph/50-60Hz
0324150120	Control lamp 24V, yellow
0326701020	PC board control MFS/SFS
0328050120	Main switch VCO
0328290010	Reset/start button
0328400130	Thermal relay NTR 4.0-6.3A
0328410110	Relay LS 5.10
0334100200	Transformer 50W/24V 115/230/400V
0340000110	Fuse 2,0 A
0360000020	Buzzer MFS-BIA/SCS
0401102020	Neoprene ring
0507260010	Manual Euromate MFS
0609590110	Starlock 22 mm
0612010220	Adjusting ring 19x1
0703030350	Spring cleaning unit
0708020140	Aluminium fan wheel
0801400010	Housing FAN 14/28/MNF/mobile units, motor side
0805030010	Wheel Ø 250 mm black
0805040010	Swivel castor Ø 125 mm with brake
0805040050	Swivel castor Ø 125 mm without brake
0806014020	Cover star knob M8
0830301030	Sealing dust drawer
0830301050	Sealing
0840101030	Bush Ø 203 mm
9824000020	Pressure difference switch MFS (800 Pa)
9850060110	Filter FCC 30-BIA

Exploded view MFS

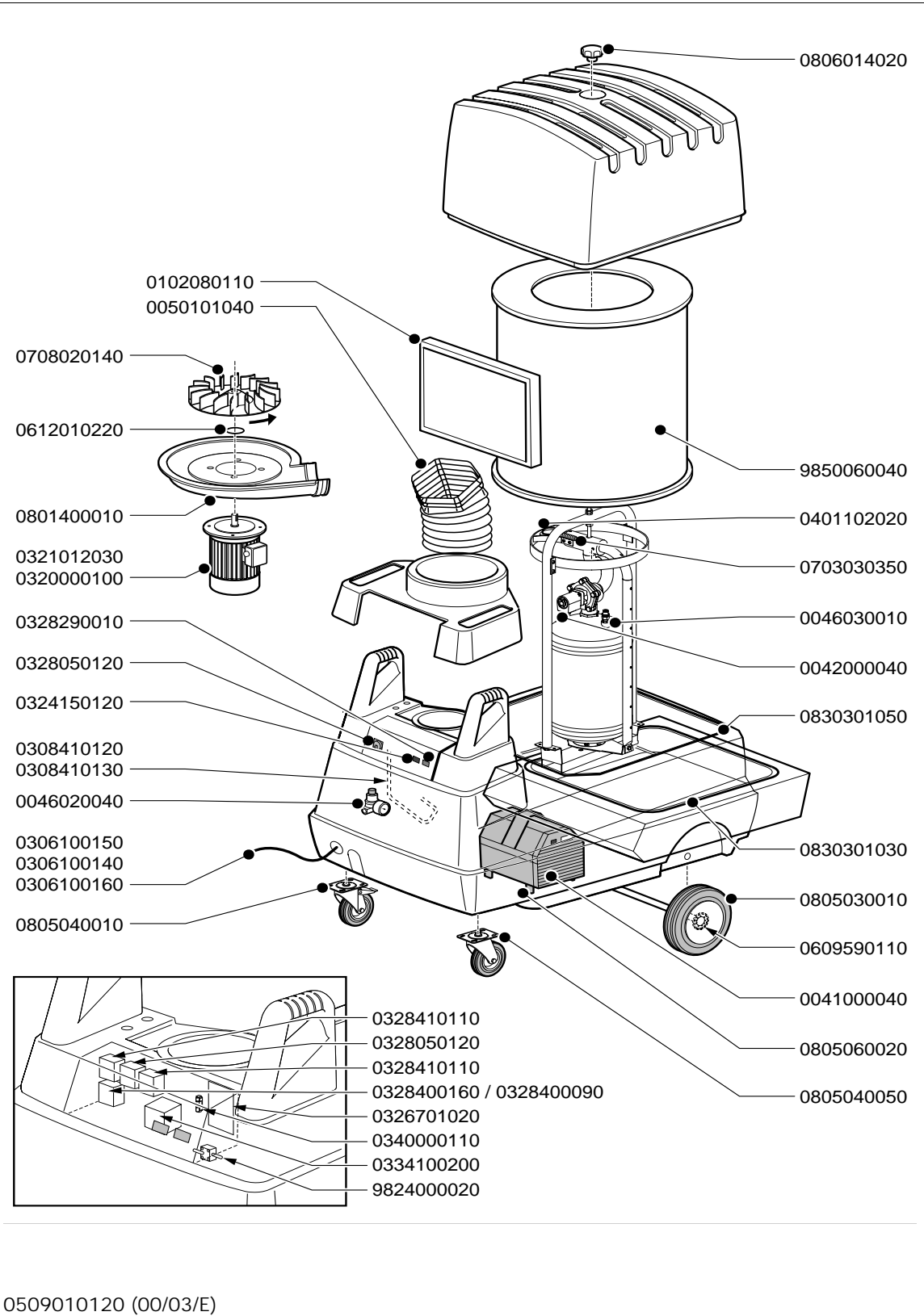

Spare parts MFS/C (400V/3ph/50Hz)

7045200000

Art. no.	Description
0041000040	Compressor unit MFS 230V/1ph
0042000040	Membrane valve
0046030010	Pressure relief valve 8-12 bar
0050101040	Hose set (Ultra)Flex
0102080110	Spark arrester MFS/SFS
0306100150	Mains flex MFS 5x1,5 mm ²
0308410120	Motor cable mobile units 4x1 mm ²
0320000100	Motor 0,75kW, 230-400V/3ph/50Hz
0324150120	Control lamp 24V, yellow
0326701020	PC board control MFS/SFS
0328050120	Main switch VCO
0328290010	Reset/start button
0328400090	Thermal relay NTR 1.7-2.4A
0328410110	Relay LS 5.10
0334100200	Transformer 50W/24V 115/230/400V
0340000110	Fuse 2,0 A
0401102020	Neoprene ring
0507260010	Manual Euromate MFS
0609590110	Starlock 22 mm
0612010220	Adjusting ring 19x1
0703030350	Spring cleaning unit
0708020140	Aluminium fan wheel
0801400010	Housing FAN 14/28/MNF/mobile units, motor side
0805030010	Wheel Ø 250 mm black
0805040010	Swivel castor Ø 125 mm with brake
0805040050	Swivel castor Ø 125 mm without brake
0805060020	Shock absorber 25x20 55 gr.
0806014020	Cover star knob M8
0830301030	Sealing dust drawer
0830301050	Sealing
0840101030	Bush Ø 203 mm
9824000020	Pressure difference switch MFS (800 Pa)
9850060040	Filter FCC 30

Spare parts MFS/C (230V/3ph/50Hz)

7043200000

Art. no.	Description
0041000040	Compressor unit MFS 230V/1ph
0042000040	Membrane valve
0046030010	Pressure relief valve 8-12 bar
0050101040	Hose set (Ultra)Flex
0102080110	Spark arrester MFS/SFS
0306100140	Mains flex mobile units 4x1 mm ²
0308410120	Motor cable mobile units 4x1 mm ²
0320000100	Motor 0,75kW, 230-400V/3ph/50Hz
0324150120	Control lamp 24V, yellow
0326701020	PC board control MFS/SFS
0328050120	Main switch VCO
0328290010	Reset/start button
0328400120	Thermal relay NTR 3.0-4.7A
0328410110	Relay LS 5.10
0334100200	Transformer 50W/24V 115/230/400V
0340000110	Fuse 2,0 A
0401102020	Neoprene ring
0507260010	Manual Euromate MFS
0609590110	Starlock 22 mm
0612010220	Adjusting ring 19x1
0703030350	Spring cleaning unit
0708020140	Aluminium fan wheel
0801400010	Housing FAN 14/28/MNF/mobile units, motor side
0805030010	Wheel Ø 250 mm black
0805040010	Swivel castor Ø 125 mm with brake
0805040050	Swivel castor Ø 125 mm without brake
0805060020	Shock absorber 25x20 55 gr.
0806014020	Cover star knob M8
0830301030	Sealing dust drawer
0830301050	Sealing
0840101030	Bush Ø 203 mm
9824000020	Pressure difference switch MFS (800 Pa)
9850060040	Filter FCC 30

Spare parts MFS/C (230V/1ph/50Hz)

7042200000

Art. no.	Description
0041000040	Compressor unit MFS 230V/1ph
0042000040	Membrane valve
0046030010	Pressure relief valve 8-12 bar
0050101040	Hose set (Ultra)Flex
0102080110	Spark arrester MFS/SFS
0306100160	Mains flex mobile units 3x1,5 mm ²
0308410130	Motor cable mobile units 3x1,5 mm ²
0321012030	Motor 0,75kW, 115-230V/1ph/50-60Hz
0324150120	Control lamp 24V, yellow
0326701020	PC board control MFS/SFS
0328050120	Main switch VCO
0328290010	Reset/start button
0328400130	Thermal relay NTR 4.0-6.3A
0328410110	Relay LS 5.10
0334100200	Transformer 50W/24V 115/230/400V
0340000110	Fuse 2,0 A
0401102020	Neoprene ring
0507260010	Manual Euromate MFS
0609590110	Starlock 22 mm
0612010220	Adjusting ring 19x1
0703030350	Spring cleaning unit
0708020140	Aluminium fan wheel
0801400010	Housing FAN 14/28/MNF/mobile units, motor side
0805030010	Wheel Ø 250 mm black
0805040010	Swivel castor Ø 125 mm with brake
0805040050	Swivel castor Ø 125 mm without brake
0805060020	Shock absorber 25x20 55 gr.
0806014020	Cover star knob M8
0830301030	Sealing dust drawer
0830301050	Sealing
0840101030	Bush Ø 203 mm
9824000020	Pressure difference switch MFS (800 Pa)
9850060040	Filter FCC 30

Exploded view MFS

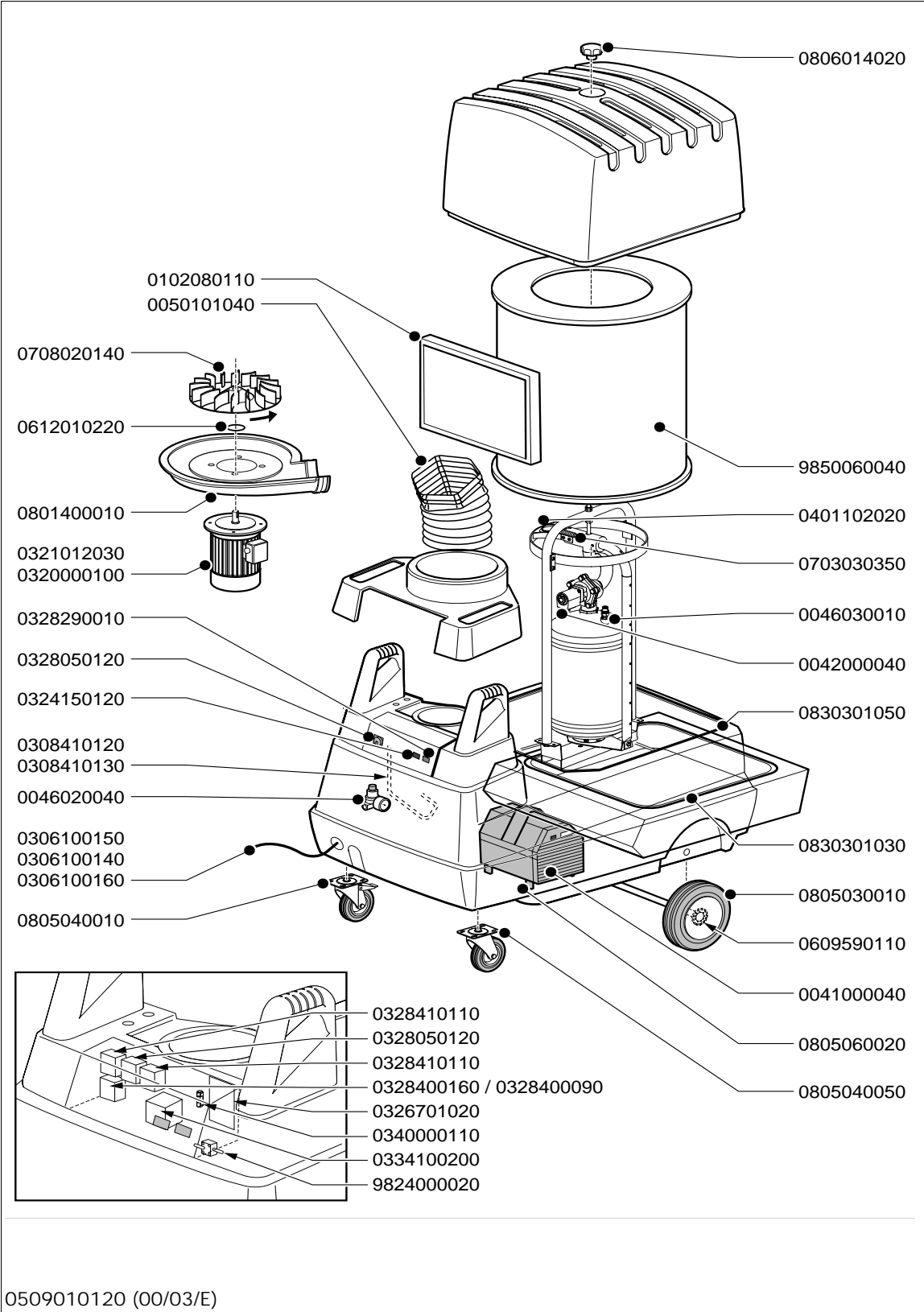

Spare parts **MFS/C-BIA (230V/1ph/50Hz)**

7042400000

Art. no.	Description
0041000040	Compressor unit MFS 230V/1ph
0042000040	Membrane valve
0046030010	Pressure relief valve 8-12 bar
0050101040	Hose set (Ultra)Flex
0102080110	Spark arrester MFS/SFS
0306100160	Mains flex mobile units 3x1,5 mm ²
0308410130	Motor cable mobile units 3x1,5 mm ²
0321012030	Motor 0,75kW, 115-230V/1ph/50-60Hz
0324150120	Control lamp 24V, yellow
0326701020	PC board control MFS/SFS
0328050120	Main switch VCO
0328290010	Reset/start button
0328400130	Thermal relay NTR 4.0-6.3A
0328410110	Relay LS 5.10
0334100200	Transformer 50W/24V 115/230/400V
0340000110	Fuse 2,0 A
0360000020	Buzzer MFS-BIA/SCS
0401102020	Neoprene ring
0507260010	Manual Euromate MFS
0609590110	Starlock 22 mm
0612010220	Adjusting ring 19x1
0703030350	Spring cleaning unit
0708020140	Aluminium fan wheel
0801400010	Housing FAN 14/28/MNF/mobile units, motor side
0805030010	Wheel Ø 250 mm black
0805040010	Swivel castor Ø 125 mm with brake
0805040050	Swivel castor Ø 125 mm without brake
0805060020	Shock absorber 25x20 55 gr.
0806014020	Cover star knob M8
0830301030	Sealing dust drawer
0830301050	Sealing
0840101030	Bush Ø 203 mm
9824000020	Pressure difference switch MFS (800 Pa)
9850060110	Filter FCC 30-BIA